

Tune-up Kit Instructions

Jake Brake® Models 336/A

P/N 019469

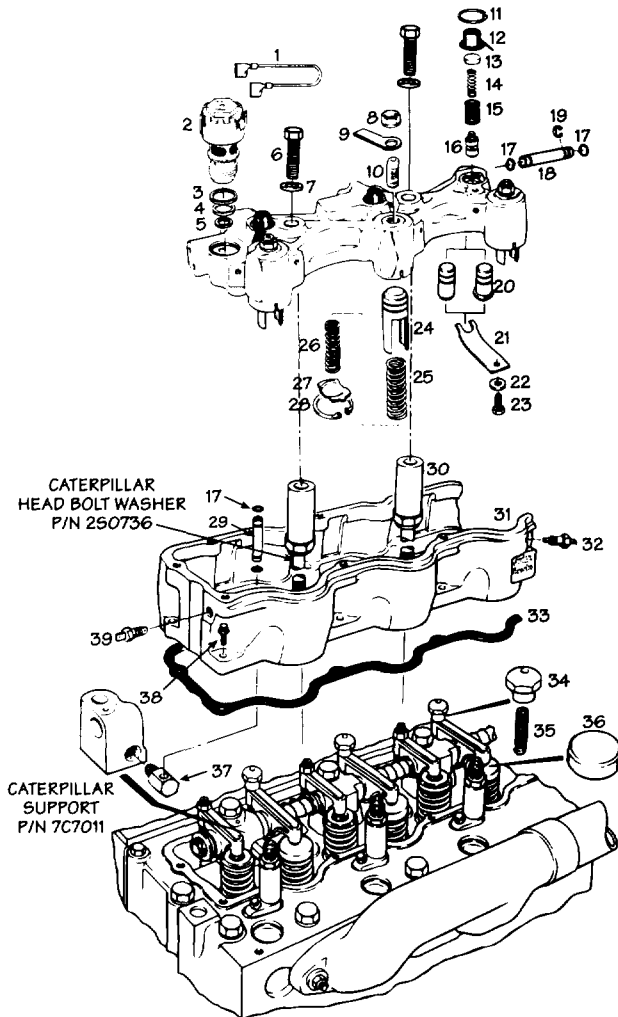

Tune-up Kit Contents

Illus. No.	P/N	Part Name	Quantity
1	020820	Solenoid harness	2
3	020229	Upper seal ring	2
4	001082	Center seal ring	2
5	001083	Lower seal ring	2
9	018995	Tab set (Model 336A only)	1
11	011284	Retaining ring	6
12	011252	Control valve cover	6
13	014431	Control valve shim	6
14	007500	Control valve inner spring	6
15	010843	Control valve outer spring	6
16	011930	Control valve	6
17	014439	O-ring	4
19	014540	E-ring	1
21	013428	Master piston flat spring	6
22	001030	Washer	6
23	021740	Hex capscrew	6
39	017657	Terminal leadout w/O-ring	2
NI	019474	Instructions	1

Instructions

For additional information on the Caterpillar 336 series engine brake, refer to Jacobs Engine Brake Installation Manual, P/N 014744.

Use OSHA-approved cleaning solvent for cleaning parts. Original parts to be reused should be inspected for wear and replaced as required. Wear safety glasses where indicated.

Access Engine Brake

1. Thoroughly clean engine.
2. Remove accessory equipment to gain access to the valve cover and remove.
3. Disconnect the electrical connections at the spacer (2 locations).
4. Remove the engine brake housing capscrew (6) and washers (7). Remove the housings.
5. Remove the seal rings (17) from the oil supply adapter (18) and supply tube (29). Remove the terminal leadout assemblies (37). Discard the seal rings and leadout assemblies.



Disassemble Housings

1. Remove the solenoid harness (1) and valve (2). Discard the three seal rings (3, 4, 5).



WEAR SAFETY GLASSES. REMOVE THE CONTROL VALVE COVERS (12) CAREFULLY TO AVOID PERSONAL INJURY. COVERS ARE UNDER LOAD FROM THE CONTROL VALVE SPRINGS (14, 15).

2. Hold down the control valve cover while removing the retaining ring (11). Remove and discard the springs (14, 15), control valves (16), covers (12), retaining rings (11) and shims (13).
3. Remove the master piston (20); discard the flat spring (21), washer (22) and capscrew (23). Save the master piston.

Assemble Housings

1. Clean the housings and all parts in approved cleaning solvent. Dry with compressed air.
2. Coat all parts to be installed into housings with clean lube oil.
3. Install the new control valves, springs and capscrews. Reinstall the original cover.
4. Install the original master pistons with the new flat springs, washers and capscrews.

NOTE:
WHEN TIGHTENING THE SCREWS, BE SURE THAT THE SPRING LEGS ARE CENTERED AROUND THE MASTER PISTON BOSS.

6. Install the lower (smallest) solenoid seal ring in the bottom of the solenoid valve bore and the upper and center seal rings on the solenoid valve. The new upper seal ring, P/N 020229, can be used on all solenoids. It can be identified by a yellow stripe.
7. Insert the solenoid in the bore. Solenoids, P/N 020236 and 020239, should be torqued to 168 - 192 lb.-in. (19 - 21.7 N•m). All other solenoids should be torqued to 110 lb.-in. (12 N•m).

Install Engine Brake Housings

Lubricate the seal rings and install on the Jacobs oil supply feed tube. Install the tube into the hole in the oil supply fitting located in the rear rocker shaft support bracket.

NOTE:
THE OIL SUPPLY FEED TUBE IS SHORTER THAN THE OIL SUPPLY JUMPER TUBE AND HAS NO SNAP RING GROOVE.

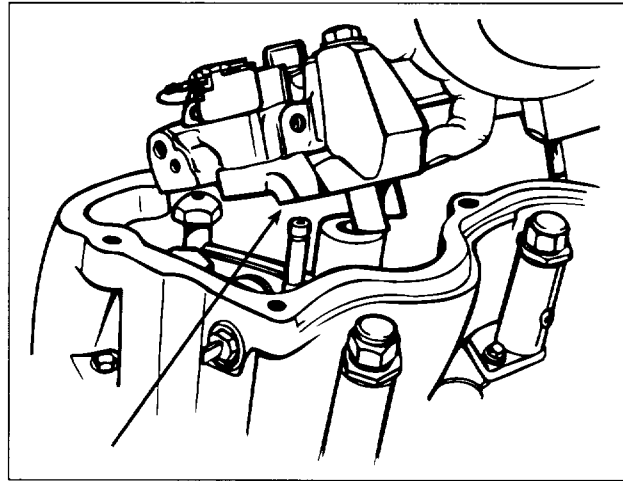

FIG. 1

Set the **rear** housing in place (Fig. 1), making sure that the oil supply feed tube enters the hole in the bottom of the housing.

Coat the capscrew threads and both faces of the related washers with a moly lube (Caterpillar P/N 6V4876 or G-N metal assembly paste or equivalent) prior to assembly.

Install the washers from the cylinder head capscrews on the Jacobs capscrews and install them through the housing, supports, and into the cylinder head. Position the housing so that the slave pistons are centered over the valve caps. Hand tighten the capscrews.

NOTE:
THE CAPSCREWS SHOULD BE HAND TIGHTENED ONLY TO PERMIT ALIGNMENT OF HOUSINGS.

Lubricate and install the oil seal rings on the jumper tube. Insert the E-ring into the groove. Insert the tube into the front housing all the way to the E-ring (Fig. 2).

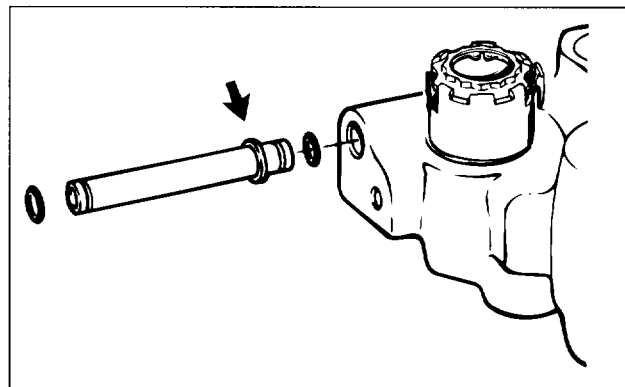

FIG. 2

Install the front housing following the same procedures as the rear housing installation.

Align the front and rear housings so that the upper tube can be extended from the front housing and inserted into the rear housing (Fig. 3).

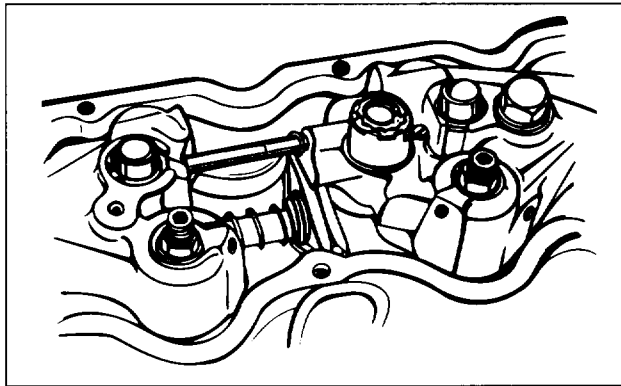

FIG. 3

Tighten the housing capscrews evenly using the following increments:

- 60 lb.-ft. (82 N•m)
- 120 lb.-ft. (163 N•m)
- 150 lb.-ft. (200 N•m)
- 150 lb.-ft. (200 N•m) - final torque check

Application and Adjustment Information

Brake Model	Engine Model/ Model Year	Slave Lash	Adjusting Tool P/N
336A	9TL & 7RJ, 3306C (with 1/2" diameter exhaust push tubes)	0.135"	018989
C336	9TL & 7RJ, 3306C	0.035"	014767
C336	63Z3300 & greater, 5KD & 13Z, 3306B; 76R6115 & greater, 3306	0.035"	014767

Slave Piston Adjustment

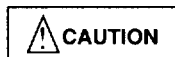

FOLLOW ADJUSTMENT PROCEDURES EXACTLY. ANY OTHER METHOD OF ADJUSTING THE SLAVE PISTON CLEARANCE IS NOT AUTHORIZED BY JACOBS AND MAY RESULT IN SERIOUS ENGINE AND/OR ENGINE BRAKE DAMAGE.

Slave piston adjustment must be made with the engine stopped and cold. The exhaust valve on the cylinder to be adjusted must be in the closed position. Follow the sequence indicated in the table below.

Slave Piston Adjustment

Set Engine	Set Clearance on Cyl. No.
Cyl 1 TDC Comp	1, 3, 5
Cyl 6 TDC Comp	2, 4, 6

With the exhaust valves closed (rocker arms loose), turn in the slave piston adjusting screw until the slave piston contacts the valve stem cap (Fig. 4).

NOTE:
IT MAY BE DIFFICULT TO "FEEL" THE CONTACT WITH THE VALVE CAP. USE A FLASHLIGHT TO VISUALLY SEE THE SLAVE PISTON CONTACT THE VALVE CAP.

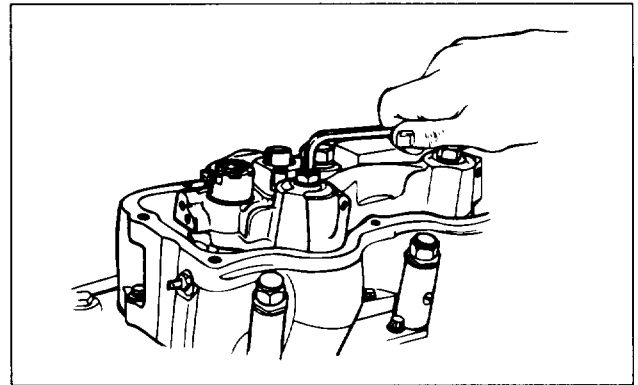

FIG. 4

Model C336 Only

Place the Jacobs lash adjusting gage, P/N 014767, over the adjusting screw and nut so that the "A" mark is in line with the wrench handle.

From this position, hold the gage in place and turn the adjusting screw out (counterclockwise) until the wrench handle lines up with the "B" mark on the gage. This will provide a slave piston clearance of 0.035" (0.89 mm).

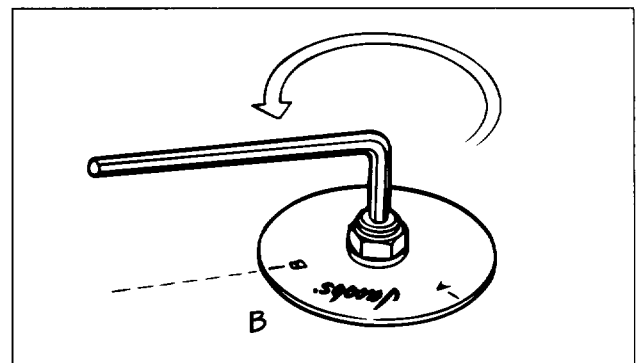

FIG. 5

Model 336A Only

Place the Jacobs slave piston adjusting gage, P/N 018989, (0.135") between the valve cap and slave piston foot. Turn the adjusting screw clockwise until a slight drag is detected (see Fig. 6).



BE SURE THAT THE FEELER GAGE IS FULLY ENGAGED UNDER BOTH SLAVE PISTON FEET. FAILURE TO PROPERLY USE THIS TOOL MAY RESULT IN INCORRECT SLAVE LASH WHICH WILL LEAD TO POOR PERFORMANCE AND/OR ENGINE/ENGINE BRAKE DAMAGE.

Hold the adjusting screw and torque the locknut to 25 lb.-ft. (35 N•m). Continue adjusting the remaining slave pistons following the sequence in the table on page 3.

Install the terminal leadouts in the spacer and connect the solenoid lead wires to the terminal lead outs.

Replace the rocker housing covers and torque cover capscrews to Caterpillar specifications. Replace any engine components.

To ensure proper engine brake operation, check the engine brake wiring and switch adjustments. Make corrections as needed.

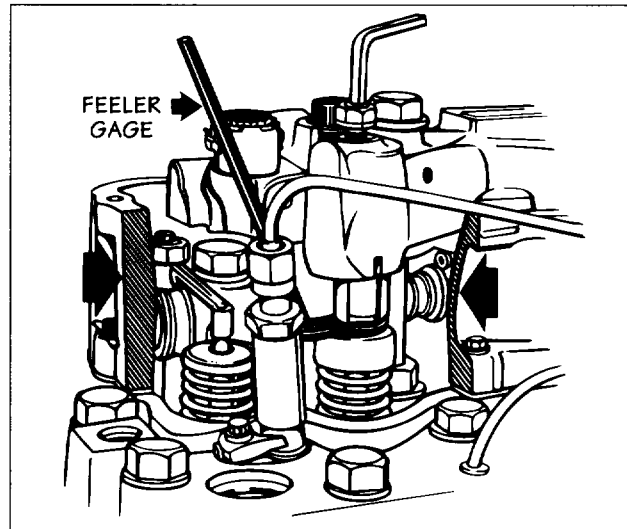

FIG. 6

Jacobs®

Jacobs® and Jake Brake® are registered trademarks of
Jacobs Vehicle Equipment Company
22 East Dudley Town Road • Bloomfield CT 06002

© 1996 Jacobs Vehicle Equipment Company
Printed in USA 4/96 P/N 019474B